

5 AXES MACHINING CENTER DECKEL MAHO DMC 80 U duoBLOCK



TECHNICAL DATA

CNC Heidenhain iTNC 530 HSCI

RACING:

X axis travel:

mm 800

Y axis travel:

mm 1.050

Z axis travel:

mm 800

B axis travel:

180°

C axis travel:

360°

ADVANCEMENTS:

Rapid feed speed in the X, Y, Z axes:

mm/min 40,000

Acceleration in the X, Y, Z axes:

m/s² 2,7 / 6,5 / 6,5

ELECTRO SPINDLE:

Electrospindle rotation speed:	rpm 18,000
Tool attachment cone:	ISO 40
Electrospindle power:	kW 35
Torque:	Nm 130

TABLE:

Fixing surface:	mm 800 x 630
Maximum capacity:	kg 1.000

Machine equipped with:

- Tool changer 240 positions
- Heidenhain TS640 workpiece probe
- Tool breakage control in the warehouse
- QuickSET 3D predisposition
- High pressure through the spindle 40 bar
- Tank with paper filter
- Integrated fume extractor
- Tool loading/unloading side control panel
- Power failure protection package
- FASTEMS automation preparation
- Instruction manuals and CE declaration

Year of construction: 2011

Diagramma coppia, diagramma potenza 32/44kW

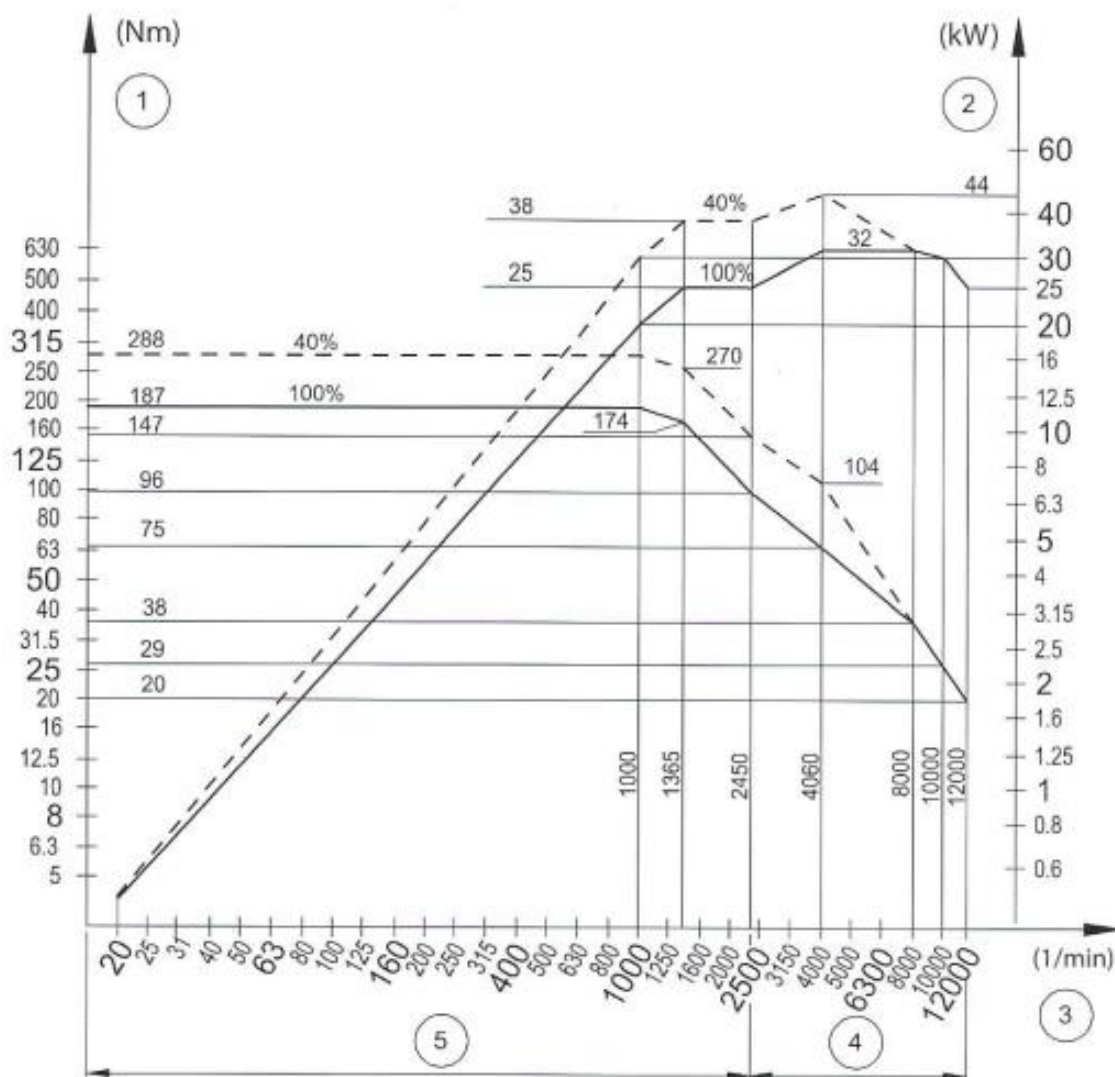

Fig. 4-1

- | | | | |
|---|----------------|---|---------------------------|
| 1 | Coppia | 4 | Funzionamento a triangolo |
| 2 | Potenza | 5 | Funzionamento a stella |
| 3 | Numero di giri | | |

Vista dall'alto

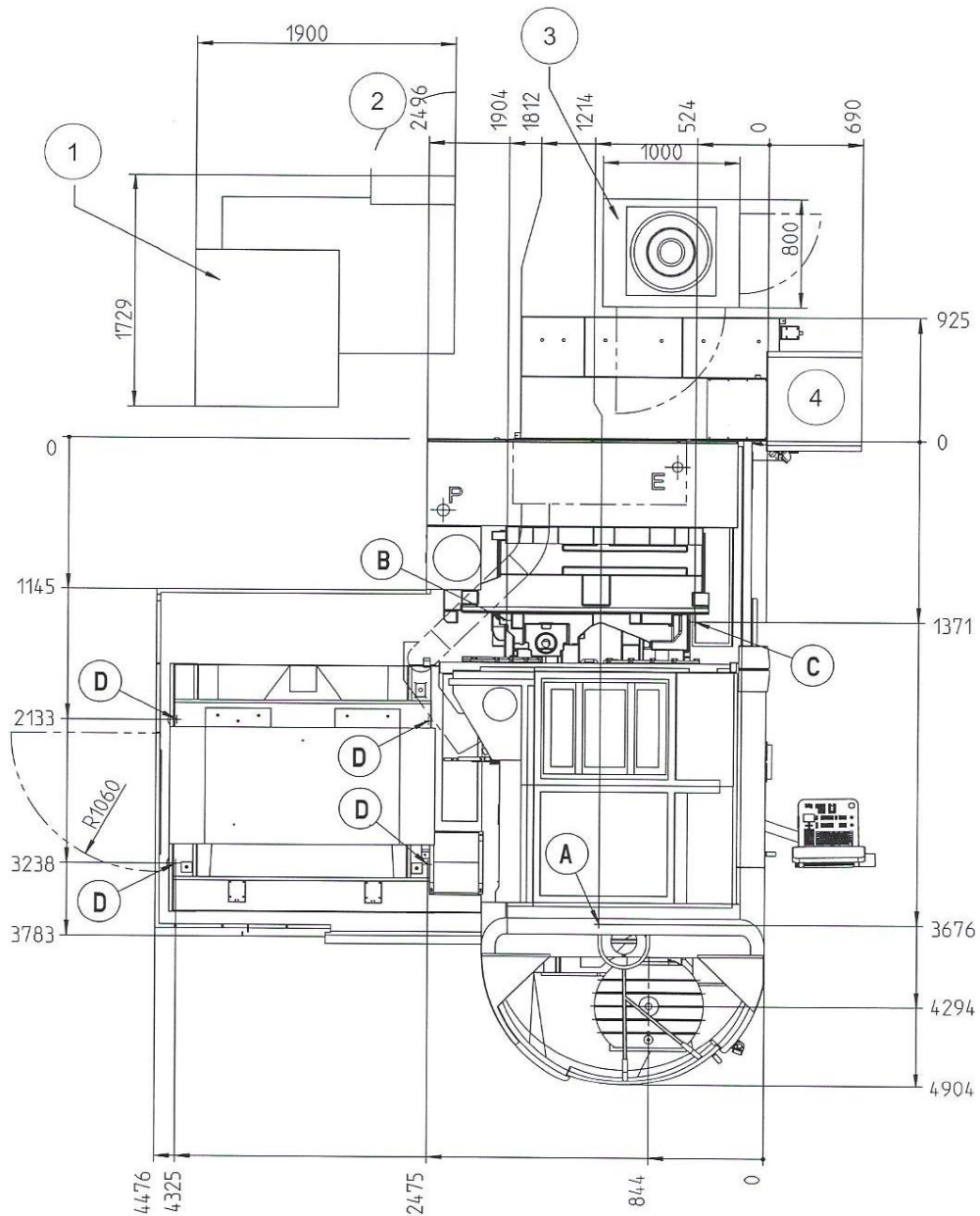

Fig. 9-4

- | | | | |
|---|--|---|---------------------------|
| 1 | Filtro a nastro 980 I | 3 | Unità di raffreddamento |
| 2 | Larghezza di trasporto senza magazzino | 4 | Trasportatore di trucioli |